



TAYLOR FORGE
Engineered Systems, Inc.

Slug Catchers



**Engineered Solutions to
Separation Problems**

Separation Products from Taylor Forge

Taylor Forge Engineered Systems has been a leading manufacturer of liquid separation equipment for the pipeline industry for over forty years. We design and manufacture all types of vessels, components, sub-assemblies and complete systems for liquid separation and storage. Our extensive experience in component manufacturing and knowledge of field construction has helped us design products that minimize costs and installation time.

Each liquid separation system has its own unique characteristics and must be examined on a case-by-case basis. This bulletin concentrates on the separation and storage of large volume liquids from natural gas. We do, however, furnish all sizes of systems.

Horizontal Separator Vessel

- Can give small particle separation (10 microns) where there is more liquid and lower gas flow.
- Useful as three phase separator.
- Becomes expensive and heavy when large sizes are required.
- Good separation up to 5 - 700 bbls. slug size.

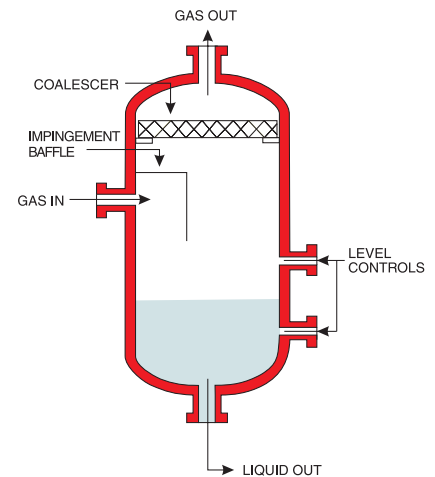
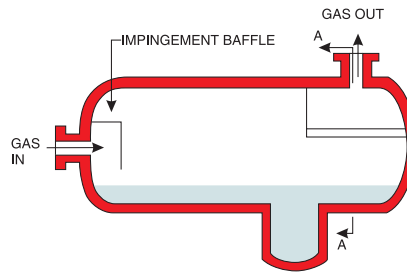

Vertical Separator Vessel

- Useful where small particle separation (10 microns) is required and gas flow is large in relation to liquid slug size.
- Equipment is expensive and heavy when large sizes are required.
- Good separation -- useful up to 5 - 700 bbls. slug size.

Pipe Fitting Type Slug Catcher

- Very economical where small liquid slugs are to be caught.
- Particle separation is poor and relatively unpredictable.
- Catches slugs up to 150 - 200 bbls.

This type of separation equipment typically has an impingement plate to knock out bulk liquids and a vertical column to form a gravity type separator, but it usually has insufficient area to effectively remove small particles. Normally, it is just used to catch the slugs of liquid and hold them. For economic reasons, these slug catchers are usually designed as pipe and fittings, rather than as pressure vessels.

The pipe fitting type slug catcher provides good slug separation and slug storage volume at a reasonable cost. Small particle separation is poor, but it improves at low flow rates. A slug catcher of this type can be used to protect a centrifugal type separator and the combination will give separation and slug storage capacity.

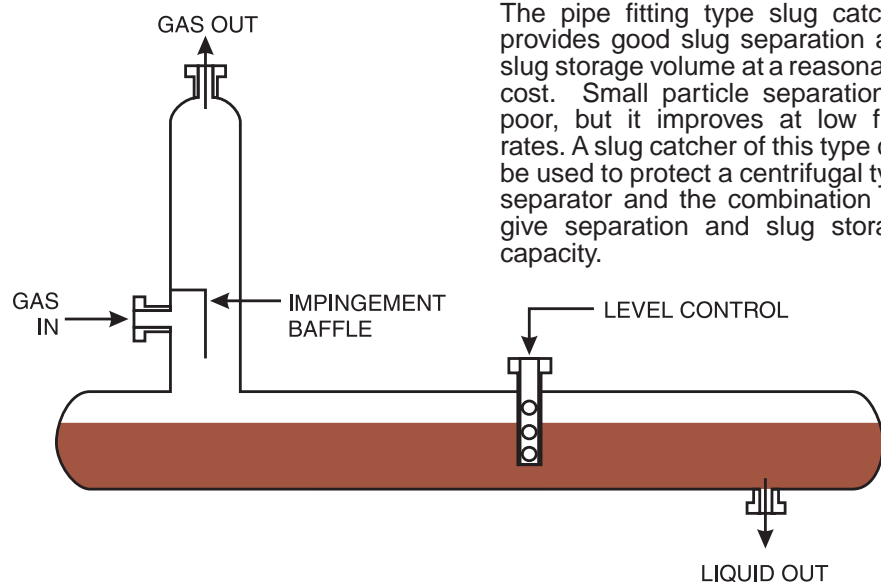

Harp Type Separator/Slug Catcher

- ❑ Economical way to catch large slugs (thousands of barrels).
- ❑ Gives predictable particle separation in the 50 micron and up sizes.
- ❑ Predictable separation up to tens of thousands of barrels slug size.
- ❑ Ships in pieces for field assembly with line pipe.
- ❑ When slug size is large enough to justify the logistics of field assembly, and B31.8 type construction is allowed, the harp type separator/slug catcher will be considerably cheaper than vessels.

The Taylor Forge Engineered Systems harp type separator/slug catcher is a versatile device for catching slugs and separating liquid and solid particles from pipeline gas. It is built from high strength material and in its larger sizes can offer cost and delivery savings over vessel type slug catchers.

The units can be furnished completely engineered including the pig trap, separator/slug catcher, foundation and instrumentation. The separator/slug catcher can be buried below ground or placed on piers above ground as conditions require. Controls can be integrated into the existing systems. The system can be split in two halves for redundant operation and/or sequential construction.

Effective level controls are normally installed, including a vent line from a level column near the liquid manifold to the gas out manifold. With proper interconnections and the addition of interface controls, the sludge manifold can be used to effectively separate water from hydrocarbon liquids. If liquid particles smaller than 50 microns are to be removed from the gas stream, separator elements can be added to the dry gas manifold or downstream of the slug catcher.

Depending on various conditions or the particular application, the basic design configuration may be easily modified. The use of multiple slopes and/or elbows allow the slug catcher to be filled to a higher level without danger of re-entrainment and carryover of liquid. The use of reducers and/or a two-level arrangement allows the separation and storage tubes to be different sizes for economy and more efficient operation. The two-level arrangement also shortens the installation and allows the bulk of the liquid to be diverted from the gas stream prior to the separation of the smaller particles.

The separator/slug catcher consists of several modules — distribution header, separation chambers, dry gas risers, storage harps, and liquids and sludge manifolds.

The **distribution manifold** takes the incoming gas/liquid stream, slows it down, and splits it into several smaller streams to allow uniform flow into the separation chambers.

In the **separation chambers**, the majority of the gas/liquid separation is accomplished. The required length, size and number of these chambers is a combined function of gas flow, gas chemistry and other known conditions.

The primary function of the dry **gas risers** is to deliver dry gas back into the system. As some secondary separation occurs here, their sizing is important.

The **storage harps** hold the liquids at line pressure and the number and length of these harps is determined by the storage requirements, i.e., slug size — 2 phase and residence time — 3 phase. Secondary separation also occurs here.

The **liquid and sludge manifolds** provide separation of the water, oil and debris. The oil and water are then removed from the storage end for further processing (oil) or reinjection (water). The debris is cleaned out on an as needed basis. When the liquid build-up in the lines is heavy and lines are long, many barrels' of liquid can collect. When pigging lines, this liquid arrives at the slugging rate and must be stored at pressure or flashed and disposed. In offshore applications and cold climates, thousands of barrels of storage may be required.



Taylor Forge Pipe Type Separator/Slug Catcher Offers a Number of Benefits and Advantages!

- ❑ **Predictable Efficiency** -- Using worst-case design, our system is able to perform separation when a vessel separator cannot.
- ❑ **"Carryover"** -- is prevented because our system is designed for worst case and unexpected slugs are handled along with the uninterrupted gas flow.
- ❑ **Ease of Installation** -- Our TF separator/slug catcher system is shipped to you in prefitted modules. The field contractor only makes circumferential butt welds to fit the system together.
- ❑ **Full Onstream Operation** -- Our slug catchers are on-line while pigging or dumping and can be automated to any degree you wish.
- ❑ **Short Lead Time** -- We reduce the time required from purchase order to operation. Our delivery is normally less than one-third the time to get a large vessel-type separator.
- ❑ **Planned Phase Addition** -- Our designs allow your company to add more capacity as gas supply increases, with minimum lead time, minimal expense and no shut-down.
- ❑ **Cost Effective** -- We offer cost savings up to 50% over conventional large OD vessel and pipe collection programs. Particular savings are realized when ANSI B31.8 design is used.
- ❑ **Large Volume Storage** -- The large volume storage is accomplished by the most economical way known -- in-line pipe or storage pipes.
- ❑ **Sludge Manifolds** -- The sludge manifold can be cleaned with on-line maintenance while unit is in operation.
- ❑ **Single Source Responsibility** -- We can supply all structural, process and mechanical engineering for your separation installation.

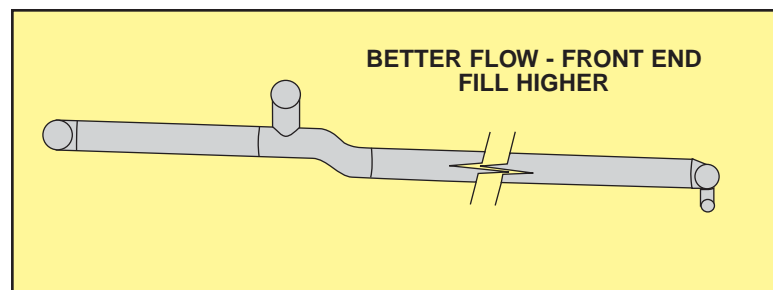
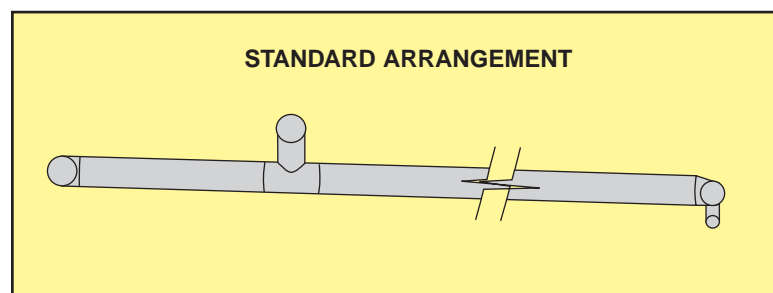
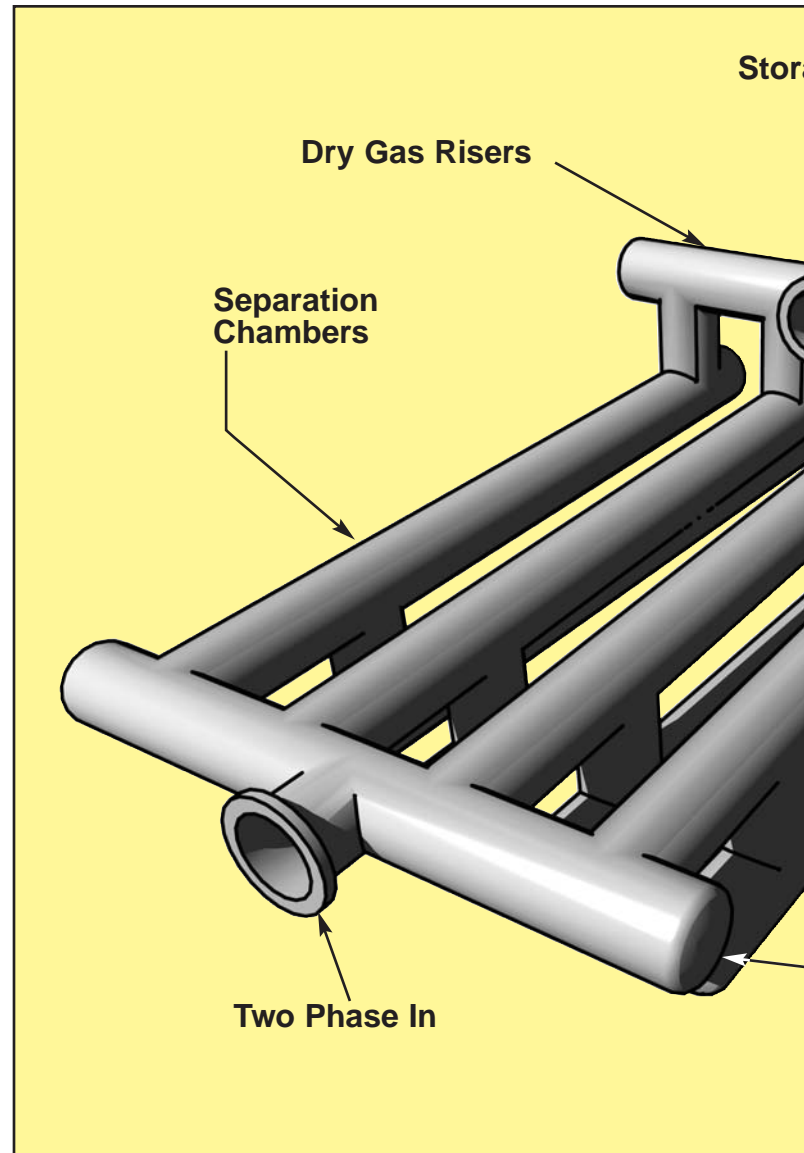

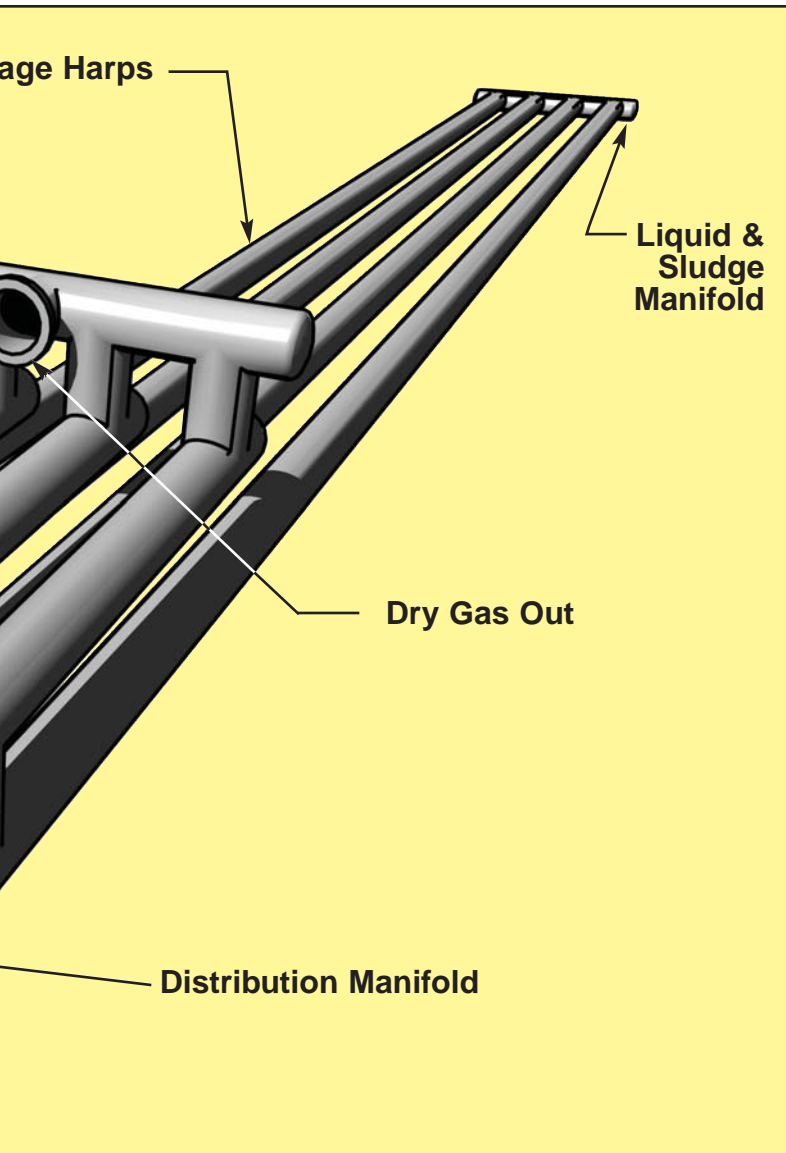

Detail of distribution header

Subsea Slug Catcher

Designed to solve the problems associated with underwater production, the Subsea Slug Catcher is a compact and modular unit, suitable for installation on the sea floor. The Subsea Slug Catcher, built into its own structure, can be dropped into place with a single lift.

Our patented Pig Bypassing Device directs liquid slugs and gas through the slug catcher while allowing the pig to bypass the slug catcher. This mechanism eliminates the need for divers to launch and receive pigs around the slug catcher.

Typical Installation of Pig Bypassing Device at Slug Catcher

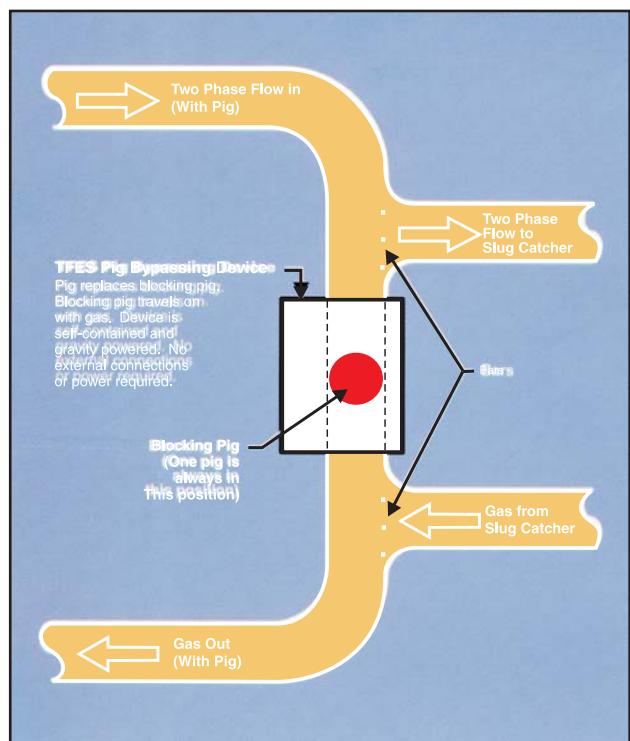
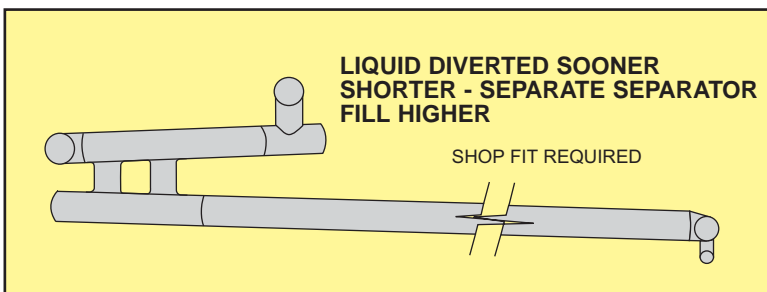
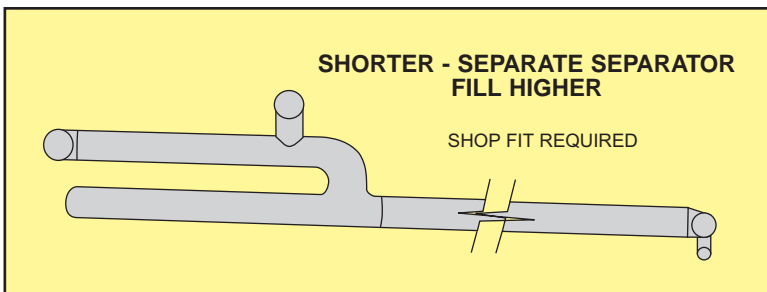

We Can Offer Complete Process and Mechanical Responsibility Based on Total Project Management

❑ VALUE ANALYSIS

What type of separator slug catcher is right for your application?

- Long term plan for field
- Design codes
- Equipment type and arrangement
- Type of material
- Type of construction

❑ PROCESS DESIGN

- Gas Conditions
- 2 or 3 phase
- Constituent analysis

- Slug Forecasting
- Line profile
- Temperature
- Performance

- Separation Efficiency
- Micron size
- Minimize carryover

- Material Balance Diagram
- Piping and Instrument Diagram
- Vent System
- Liquid Removal

❑ MECHANICAL DESIGN

- Design Code
- ANSI B31.8
- ANSI B31.3
- ASME Code
- BS5500

- Piping Flexibility Analysis
- Including all thermal and mechanical stresses
- Anchoring system
- Pigging system
- Above and below grade

❑ MANUFACTURING/ FABRICATION

- Materials
- High yield -- Y-52 to Y-70
- Carbon steel
- Low temp. with charpy's
- HIC resistant

- In-House Testing
- Charpy V-notch
- Tensiles
- Hardness --
- Brinell, Rockwell
- Weld bend

- Rolling
- Five rolls
- Hot or cold
- Max. 7-1/2" thick

- Welding
- ASME IX
- API 1104

- Closed Die Formed Extrusion
- Controlled wall thickness and radius
- Dimensional flexibility

- Heat Treating
- Normalize
- Quench and temper
- Stress relieve

- Non-Destructive Testing
- All in-house testing
- Radiography
- Ultrasonic
- Magnetic particle
- Dye penetrant

- Fabrication
- Largest pieces shippable to minimize field fabrication

- Pre-Fit and Match-Mark
- Special Coatings
- Above ground
- Below ground

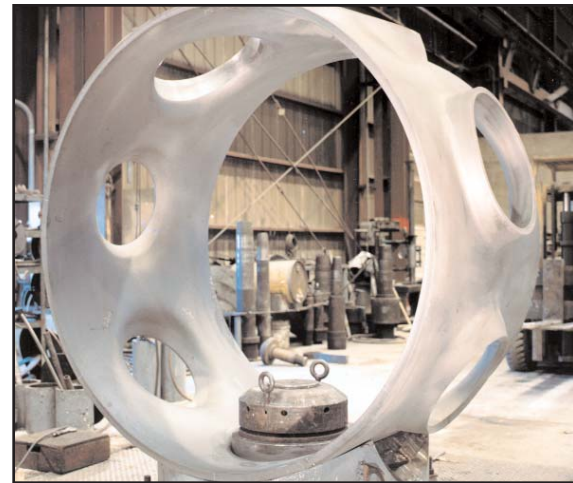



MATERIALS MANAGEMENT

- Project coordination and uniformity
- Worldwide sourcing capabilities
- Domestic sourcing as required
- Material delivery timing
- Linepipe
- Instruments
- Electrical

CIVIL DESIGN

- Optimize Site Location
- Optimize Site Utilization
 - Single level
 - Multi-level
- Facility Expansion or Grass Roots Facility

- Site Peculiarities
 - Water table
 - Weather
 - Seaside or mountains

CONSTRUCTION MANAGEMENT

- Land Survey
- Soil Sampling
- Field Weld Procedures
- Qualify & Train Field Welders
- NDT Services
- Construction Sequencing
- On-Site Surveillance

START-UP AND TRAINING SERVICES

- Start-Up System including Valve Sequencing
- Establish Operating Cycles
- Verify Performance
- Operations/Maintenance Training

QUESTIONNAIRE

Company Name _____ Phone No. _____

Address _____

Person to Contact _____

Position _____ Date _____

Pressure Design _____ Operating _____

Temperature Design _____ Operating _____

Gas S.G. _____
Composition _____

Flow Rate Design _____ Initial _____

Liquids S.G. _____
Composition _____

Flow Rate Design _____ Initial _____

Water Flow Rate Design _____ Initial _____

Estimated Liquid Slugging Rate Design _____ Initial _____

Desired Hold Up (bbls. or time) Design _____ Initial _____

Special Conditions and Site Limitations: _____

Instrumentation and controls: _____

Project timing: _____

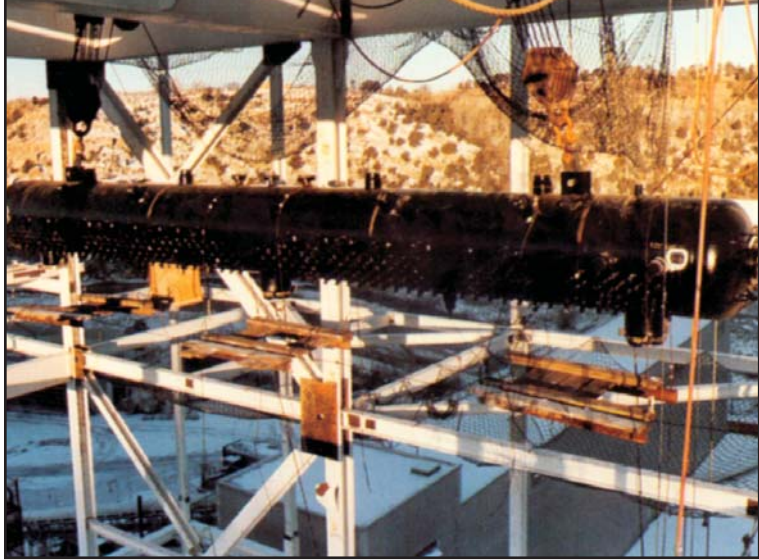

Pressure Vessels (Steam Drum)



Extruded Outlets (Air Grid Hub and Arm)



Trap with Patented Closure (Skid Mounted for Export)



Slug Catcher (Offshore Facility Utilizing Headers)



High Yield and Nuclear
Tees and Caps



12,000 psi Y-70/Y-80 Scraper Trap Skid



High Yield and Nuclear
Reducers and Elbows

Traditionally Dependable



TAYLOR FORGE
Engineered Systems, Inc.

208 N. Iron Street
Paola, Kansas 66071
Telephone: (913) 294-5331
Telex: 62192610
FAX: (913) 294-5337